

CAD FILE:

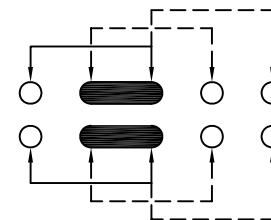

SCHEMATIC (SHORTING)

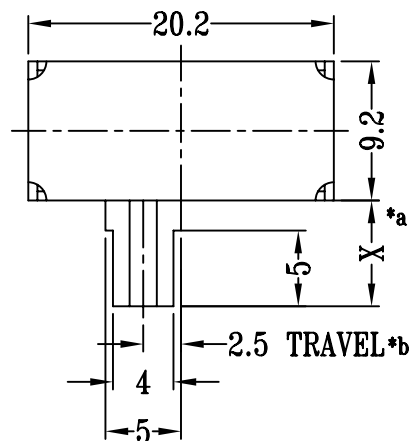
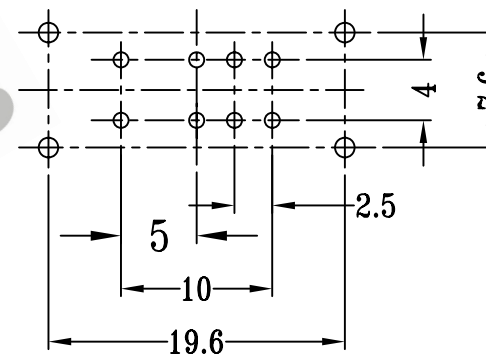
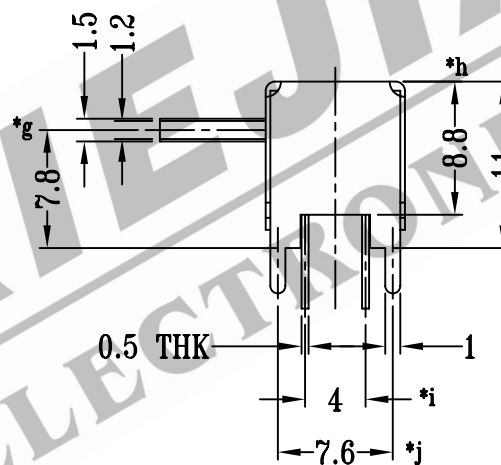
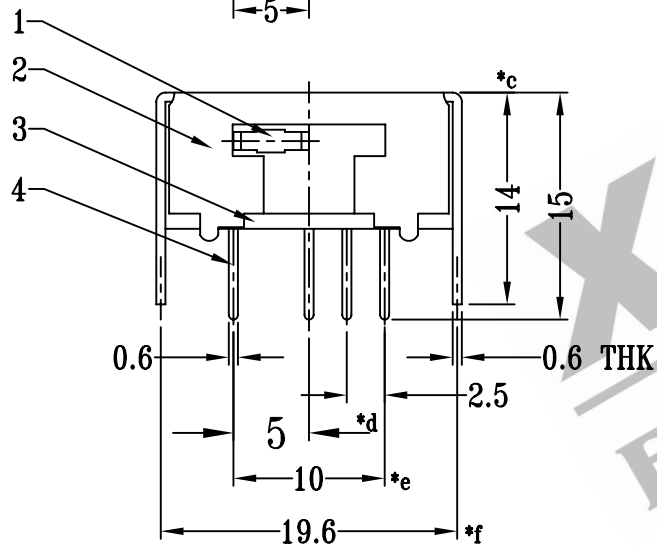

P.C.B. LAYOUT

注:带*表示关键尺寸(10个)

				TOLERANCE UNLESS SPECIFIED		SHENZHEN XIEJIA ELECTRONICS CO.,LTD.				
				WITHIN: 1.5±0.1mm		ISSUE	DATE	DESCRIPTIONS		APPD.
				OVER : 1.5±0.2mm				TITLE : HORIZONTAL SLIDE SWITCH		
8								DRWG NO.: XJ-DR-SK23E12-00		
7	STEEL BALL	STEEL	1	NATURAL				DWN.	ZHOUYU	2007-11-24
6	SPRING	STEEL WIRE	1	TEMPER				CHK'D	FANGYING	2007-11-24
5	CONATCT (CLIP)	PBS STRIP	2	Ag PLATED				APPD.	KANGXINAN	2007-11-24
4	TERMINAL	BRASS STRIP	8	Ag PLATED OVER Ni PLATED	MODEL: SK-23E12		SCALE: 2 : 1			
3	BASE	PHENOLIC RESIN	1	NATURAL	ALL MATERIALS MUST BE COMPLIANT TO ROHS					
2	FRAME	STEEL STRIP	1	Ni PLATED						
1	KNOB	POM	1	WHITE						
NO.	PART NAME	MATERIAL	Q'TY	FINISHING						